

Structural Integrity Investigation of a Deep Shaft at a Salt Mine

G Dominish, Advisian
D Ho, Advisian

Summary

Potash (K₂CO₃) is valuable as a fertilizer and it can be commercially extracted from underground deposits embedded in evaporites, such as halite or rock salt, formed by the evaporation of ancient seas. To extract the minerals vertical shafts are sunk into the ore body to provide access and extract the minerals. Above the evaporite layers, these shafts are designed for typical rock conditions and hydrostatic pressures. In the halite layers, the situation is different as, while it has a compressive strength typically in excess of 20 MPa, it is subject to significant long term creep deflections which cause significant closures around the mine shafts and mine underground roadways. These closures must be fully considered in the design of the mine and its underground structures.

One solution employed for the mine shafts is to use a concrete liner through the halite material and in such a case, it is necessary to isolate the liner from the inward and radial movement from the surrounding halite for the life of the mine. Adequate vertical support and lateral restraint for the liner is also required.

This paper presents a case study showing how a concrete shaft structure performs when the isolation system between the halite and shaft liner fails. A 3D finite element model has been used to simulate the nonlinear load-displacement behaviour of the isolation system and the transfer of halite radial and vertical movements to the liners and the support structures. In the case study this lead to significant failures of the support structures and the numerical model was able to identify the load mechanisms, test mitigation options and assist in developing an ongoing movement monitoring program to allow future operation of the shafts.

1. Introduction

The concrete structures supporting the base of the shaft liners at a salt mine experienced failure with significant cracking. The damage occurred progressively over a short timeframe with a significant amount of the visible cracking occurring in a single event.

Advanced Analysis of Advisian (WorleyParsons Group) was requested to assist in the investigation of the possible causes of the concrete support structure failures. This included assessing the true capacity of the structures and the load levels required to cause the observed damage.

The investigation included a site visit to inspect the scale and extent of the damage. A review of the remedial works was undertaken and site information on the mine operation and mine geology that could potentially affect the shaft performance was also obtained.

2. Halite Deformations during Mining

Halite rock, primarily rock salt (NaCl) and other evaporite rocks are formed by the evaporation of prehistoric seas. The halite is strong with an unconfined compressive strength typically in excess of 20 MPa and it is stable in the undisturbed state.

When it is mined by excavation or dissolution, however, it exhibits a steady-state creep behaviour induced by the shear stress around the excavation. The mechanisms and analysis of these deformations are described by Ghasemloonia. and Butt.

Prior to mining, any long term creep from the halite formation and subsequent overburden will cause the horizontal stresses in the rock to be similar to the vertical stress, leaving a state of very low shear stress and no measurable ongoing movements.

When vertical shafts and horizontal roadways are constructed in the halite, local stresses normal to the excavation are reduced to zero and significant shear stresses are created. These

stresses induce the creep behaviour described by Ghasemloonia. and Butt and it results in radial closure of the material around the shaft and inward movements at the roadways, uplift in the floor and downward movements in the roof.

The typical movements around a shaft and roadway are shown in Figure 1 and Figure 2 for a 6 m diameter shaft cut into a 150 m thick halite structure with 800 m of overburden rock. It shows radial shaft movements in the inward direction of up to 450 mm and vertical closure between the top and base of the roadway

3. Design Considerations

When designing the mine access shafts the options are:

- An unlined shaft, which has adequate clearance to allow for the radial closure of the halite strata. For this case, the potential for rock fall needs to be considered. An advantage is that if the closure is excessive, then additional material can be removed to increase the shaft size.
- A lined shaft, with an isolation gap. The liner provides protection from rock fall but closure of the isolation gap limits the effective shaft life.

It is also necessary to consider lateral displacements that can occur as a result of inclined strata.

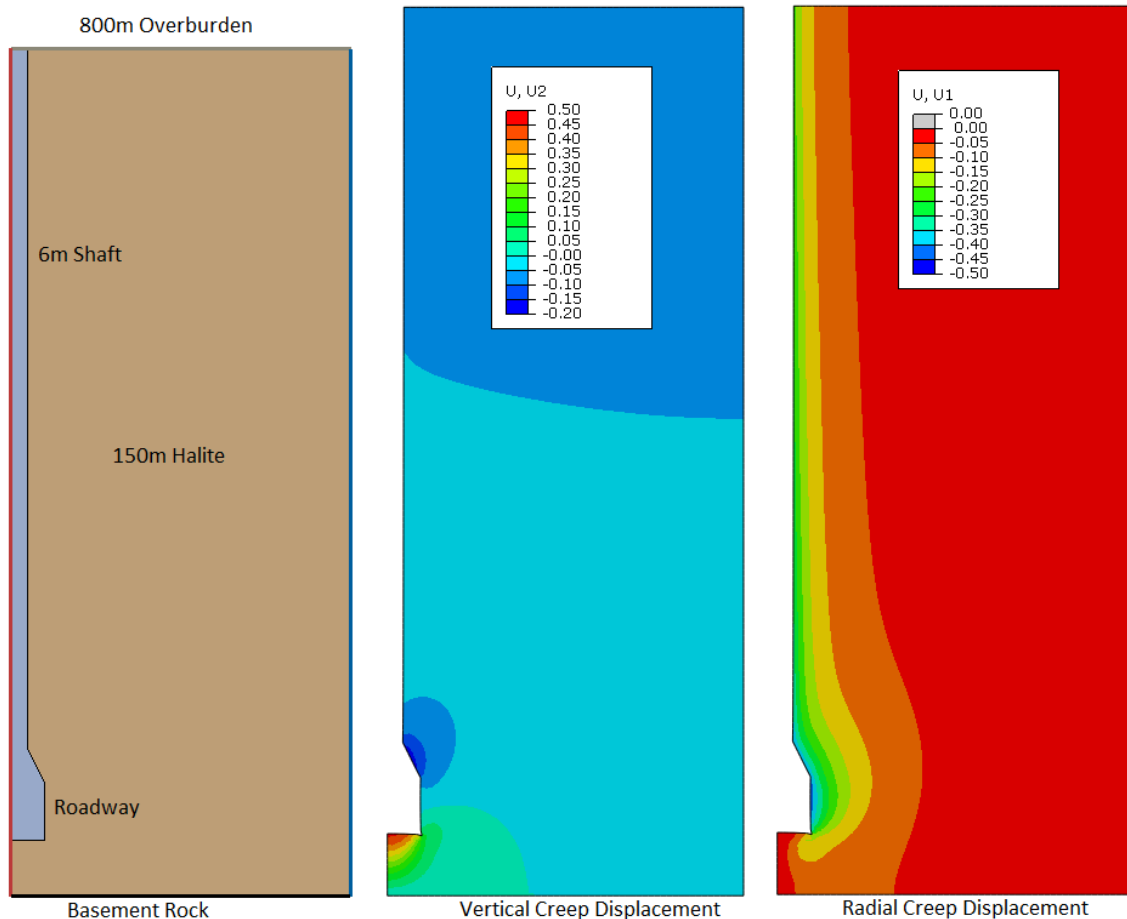

Figure 1 Shaft and Roadway Long term Typical Creep Displacement

4. Case Study

Some details of the analysis of the performance and failure of a concrete shaft structure are presented for a case where the isolation system between the halite and shaft liner fails.

A structural model of the shaft and support structure was developed and used to test the various load transfer hypotheses and compare their associated failure mechanisms with the observed damage. It was also used to examine the effectiveness of different mitigation options proposed by the mine owner and construction contractor.

4.1. Shaft Liner and Support

At the mine, the shafts are about 6 m diameter and they are sunk to the roadway level in the lower halite strata about 900 m below the ground level. The halite layers extend for about 130 m above the roadway and above that level there is about 800 m of sound sedimentary rock strata. Below the halite is harder rock.

In this case, the shaft was lined with a concrete liner. Above the halite, the liner was directly supported by the local rock strata. In the halite region, the liner was designed as isolated from the surrounding rock with a movement joint in the liner at the top of the halite and supported through the roadway to the sound rock below by a concrete

structure designed to carry the weight of the liner through the halite strata.

The roadways are generally unlined with local rock bolting to prevent spalling and an adjustable floor to accommodate local uplift near the access shafts.

The shaft liners were designed with sufficient clearance to allow 350 mm of radial closure on the shaft. The design intent was to place a flexible material into this space to contain any spalling that may occur.

An unintended consequence of the isolation material selected was that, while adequately allowing radial deformation of the shaft, it transmitted significant vertical stresses from the downward movement of the halite above the roadway onto the liner support structure. This in turn led to the failure of the support structure.

4.2. Observed movements

At this site, the observed ground movements are as follows:

- Relative vertical movement of the shaft liner: 18 mm/year
- Horizontal movement at the base of the shaft liner: 3 mm/year.
- Maximum shaft radial closure: 10 mm/year.
- Total compression of the halite layers: 10 mm/year.
- Ongoing surface subsidence in the region of the shaft from far field

effects of the mining has been observed but it is too small to cause significant issues.

4.3. Feasible mechanisms for the observed cracking

The following findings were made after the site visit.

- The shaft liner support structure failed as a result of vertical loads from the liner.
- The support structure was more than adequate for its original design loads, the weight of the liner through the halite strata.
- The source of the overloads is the relative downward movement of the salt layers directly above the structure.
- The isolation material was identified as having sufficient shear strength to transmit the loads to cause the observed failure.

4.4. Remedial Work

Following the failure of the liner support structure, the following types of remedial work was undertaken to stabilise the situation:

- The shaft liner was structurally disconnected from the failed support structure, leaving the liner supported by the original isolation material.

- A comprehensive movement monitoring program was implemented.
- The failed concrete elements of the support structure were stabilised.

5. Finite Element Analysis

A finite element (FE) model of the liner support structure was developed to determine: (1) if the reinforced concrete support structure was adequate to carry its original design loads; (2) the maximum load carrying capacity of the support structure to estimate the actual loads at cracking; and (3) the expected concrete failure locations to allow comparison with the observed cracking.

5.1. Model limitations

It should be noted that the FE model has a number of limitations as it is not a design model and it does not consider all the relevant design cases for the structure. It was used to calculate the characteristic vertical capacity of the structure but it did not consider the statistical variability in the inputs, and consequently the actual load at failure could vary from the analysis value

The model assumes quarter symmetry of the structure (Figure 3), however, in reality one corner will fail first as a result of variability in the loads and the structure as constructed. The model does not assess the load redistribution effects after the initial failure in one corner of the structure.

5.2. Finite element model

A 3D quarter model was developed as shown in Figure 3. The concrete structure was meshed with continuum solid elements. The reinforcement layers were meshed as surface elements – special type of shell elements to carry reinforcement. They were mapped onto the meshed surface of the concrete elements at the location of the significant reinforcement layers. These elements require definition of the reinforcement area, spacing and orientation, as well as the material properties for the reinforcement.

The linear elastic concrete properties used were:

- Elastic modulus = 32.5 GPa
- Poisson's ratio = 0.2
- Density = 2400 kg/m³

The concrete non-linear behaviour was modelled with the Concrete Damaged Plasticity. This, in combination with the reinforcement will calculate the ultimate capacity of the concrete structure and allows for load redistribution after initial cracking. The properties used were:

- Compressive strength: 60 MPa with the standard non-linear stress-strain curve;
- Tensile strength: 2.36 MPa with the standard post-cracking relaxation.

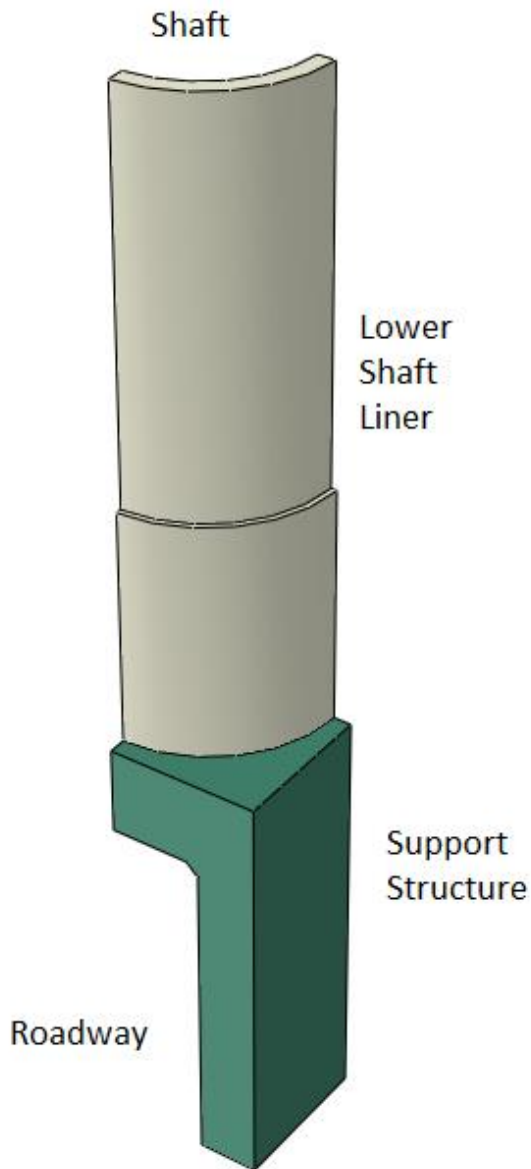

Figure 2 Geometry model of Lower Shaft Liner and Liner Support Structure

The glass fibre reinforced polymer (GFRP) rebar was modelled with the following properties:

- Elastic modulus = 65 GPa
- Ultimate strength = 1231 MPa

The bars were assumed to behave linearly until the ultimate strength was

reached, at which point rupture occurred.

Symmetry boundary conditions were applied to the symmetry planes and a full restraint condition was applied at the base of the model. Prescribed displacements were applied at the top of the shaft.

5.3. Shaft Liner Isolation Material

The shaft liner isolation material was also evaluated in a separate finite element model (Figure 4) using an appropriate material model to match supplied test data.

The analysis confirmed that the isolation material had sufficient stiffness to induce significant vertical loads on the liner structure.

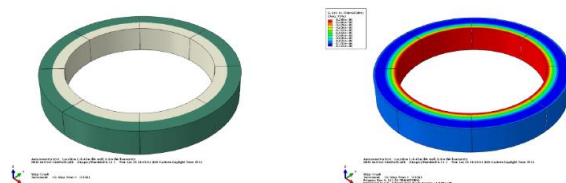

Figure 3 Liner isolation model showing materials (left) and radial stresses (right)

5.4. Analysis Results

The normalised vertical load for the entire structure is plotted against the applied displacement in Figure 5. The graph also shows the key failure points and their corresponding loads.

The development of plastic strains in the concrete structure at various load levels was determined from the finite element

analysis and these matched the site observed failure location in the shaft support structure and at the base of the

shaft liner. The locations of the failures are shown in Figure 5.

..

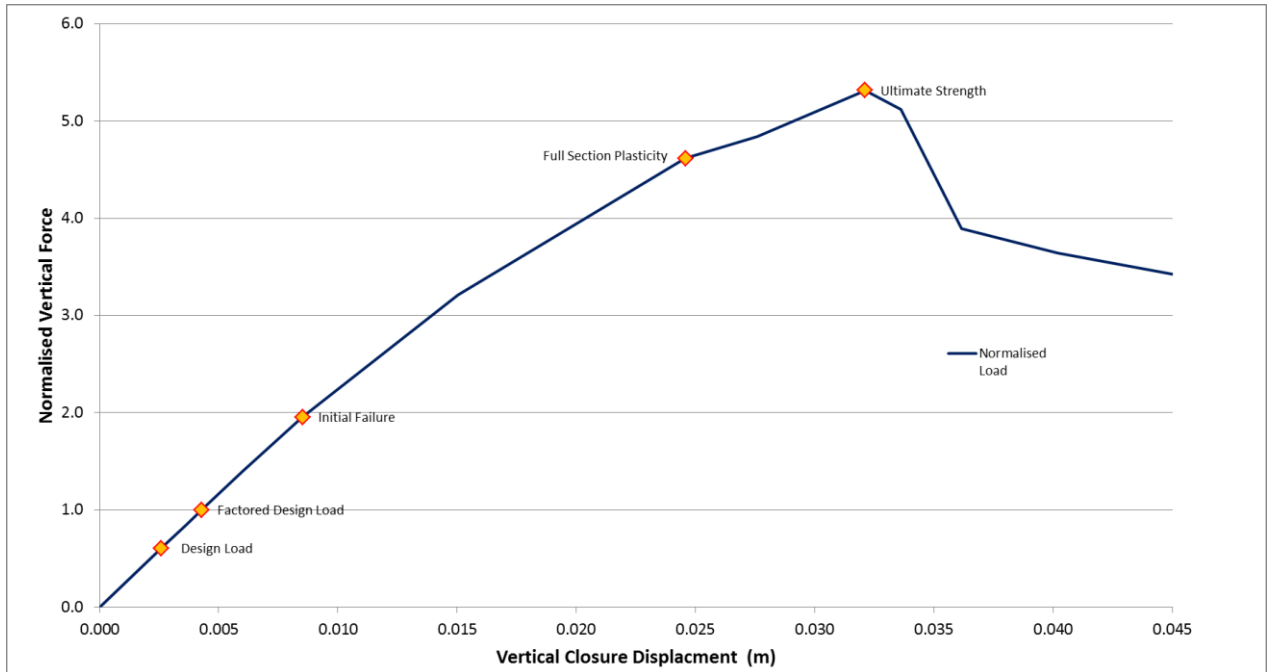

Figure 4 Load – deformation behaviour of the support structure

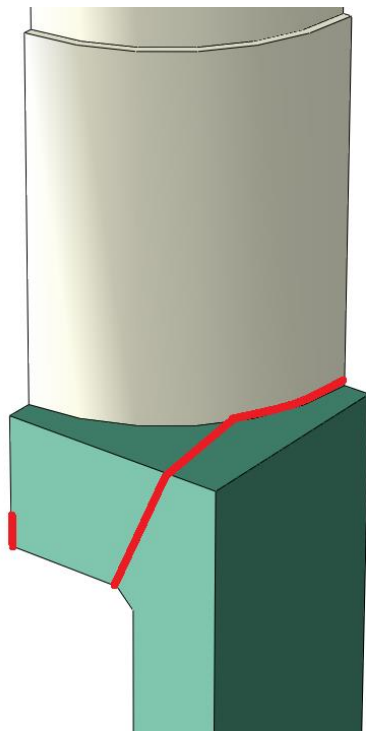

Figure 5 Failure Locations

6. Discussion

The nonlinear FE analysis has confirmed that the liner support structure failed at its weakest location. The capacity of the structure is well in excess of the intended design loads (both factored and un-factored). There was also observed crushing of concrete in the base of the shaft liner over the stiffest part of the support structure and this is consistent with the assessed load capacity.

It follows that excessive vertical load from the shaft liner was the underlying cause of the failure and the source of this load is the deformation of the halite rock layer surrounding the lower shaft.

The original design was to isolate the shaft liner from the halite with an effective void filled with an isolation material. At some point in the design process, this material was specified in a way that was not effective for vertical load transmission, and as a consequence, the liner support structure was effectively supporting the weight of the deforming strata above.

The FE analysis results showed a significant release of strain energy when the main cracking took place. This appears to be consistent with the observed events at the site.

7. Conclusions

For these types of shafts the main conclusion is that for halite materials it is essential to ensure adequate vertical isolation from the halite strata.

From a more general perspective, this work highlights the same themes that can be observed in many mine subsidence problems:

1. The need to correctly identify the expected ground movements during the design process.
2. The design of facilities so that they either transmit the design movements or be isolated from them in an effective way.
3. The establishment of the allowable operating limits for the movements.
4. The establishment of appropriate monitoring of the ground movements.

8. References

Ghasemloonia A. and Butt S.D. 2015 "Feasibility study of underground salt caverns in Western Newfoundland: experimental and finite element investigation of creep-induced damage", *Journal of Mining & Environment*, Vol.6, No.2, 2015, 205-224.